

PD6-N8918 series stepper motor with integrated controller



Option



Pin configuration of cable

SIGNAL CABLE	
FUNCTION	COLOR
Input 1	Black
Input 2	Violet
Input 3	Gray/pink
Input 4	Red/blue
Input 5	White/green
Input 6	Brown/green
Analog input	White/blue
Output 1	White/yellow
Output 2	Yellow/brown
Output 3	White/gray

SIGNAL CABLE	
FUNCTION	COLOR
RS485 Tx+	Gray
RS485 Tx-	Pink
RS485 Rx-	Yellow
RS485 Rx+	Green
CAN +	Brown
CAN -	White
Signal GND (COM)	Gray/brown
GND	blue + pink/brown
GND LOGIC	Red
+ UB LOGIC	White/pink (20-48V)

POWER CABLE	
FUNCTION	Cable no./COLOR
+ UB	1
GND	2
PROTECTIVE CABLE	Green/yellow

M16 Twintus connector pin configuration

M16 CONNECTOR 18 PIN		M16 CONNECTOR 3 PIN	
FUNCTION	PIN NO.	FUNCTION	PIN NO.
Output 1	1	+ UB	1
Output 2	2	GND	2
Output 3	3	Protective wire	3
Analog input	4		
+VB External	5		
GND	6		
RS485 Tx+	7		
RS485 Tx-	8		
RS485 Rx-	9		
RS485 Rx+	10		
Input 1	11		
Input 2	12		
Input 3	13		
Input 4	14		
Input 5	15		
Input 6	16		
CAN -	17		
CAN +	18		

Technical data

- Operating voltage:** 24 to 48 V DC
- Max. phase current:** Adjustable up to max. 10.5 A/phase, 7A nominal current
- Interface:** RS485 or CANopen
- Operating mode:** Position, speed, flag position, clock direction, analog, analog position, torque
- Position monitoring:** Automatic error correction up to 0.9°
- Operating mode:** 1/1, 1/2, 1/4, 1/5, 1/8, 1/10, 1/32, 1/64, adaptive (1/128)
- Step frequency:** 0 to 50 kHz in the clock/direction mode, 0 to 25 kHz in all other modes
- Inputs:** 6 optocoupler inputs (5..24 V), analog input
- Outputs:** Open-Drain (0 switching, max. 24 V/1.5 A)
- Current reduction:** Adjustable in 1% values
- Protection circuit:** Overvoltage and heatsink temperature > 80 °C
- Temperature range:** 0 to + 40 °C
- Connection type :** 2 x 2 m cable

Attention: An intermediate circuit capacitor of at least 4,700 µF (Z-K4700/50) must be provided on the supply voltage.

Input circuits

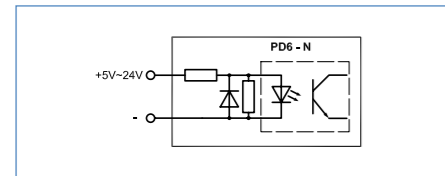

Output circuits

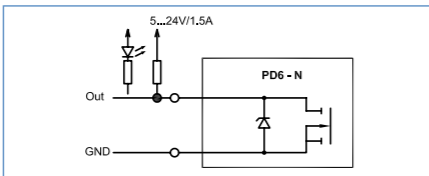

Accessories

- ZIB-PDx-N** Interface board for rapid commissioning
- ZK-RS485-USB** RS485-USB cable for PC connection
- ZK-TW-18** length 2 m Cable for Twintus connector
- ZK-TW-3** length 2 m Cable for Twintus connector
- Other lengths on request (from 50 units)

Order identifier

PD6-N8918S6404 -S
S = motor length
S = M16 Twintus connector

Available versions (others on request)

Type	Holding torque Ncm	Supply voltage Ncm	Weight kg	"A" mm	Option with Twintus connector
PD6-N8918S6404	320	24-48	1.7	89	
PD6-N8918S6404-S	320	24-48	1.7	89	X
PD6-N8918M9504	590	24-48	3.4	121	
PD6-N8918M9504-S	590	24-48	3.4	121	X
PD6-N8918L9504	930	24-48	4.0	151	
PD6-N8918L9504-S	930	24-48	4.0	151	X

Outline drawing (in mm)

PD6-N8918...

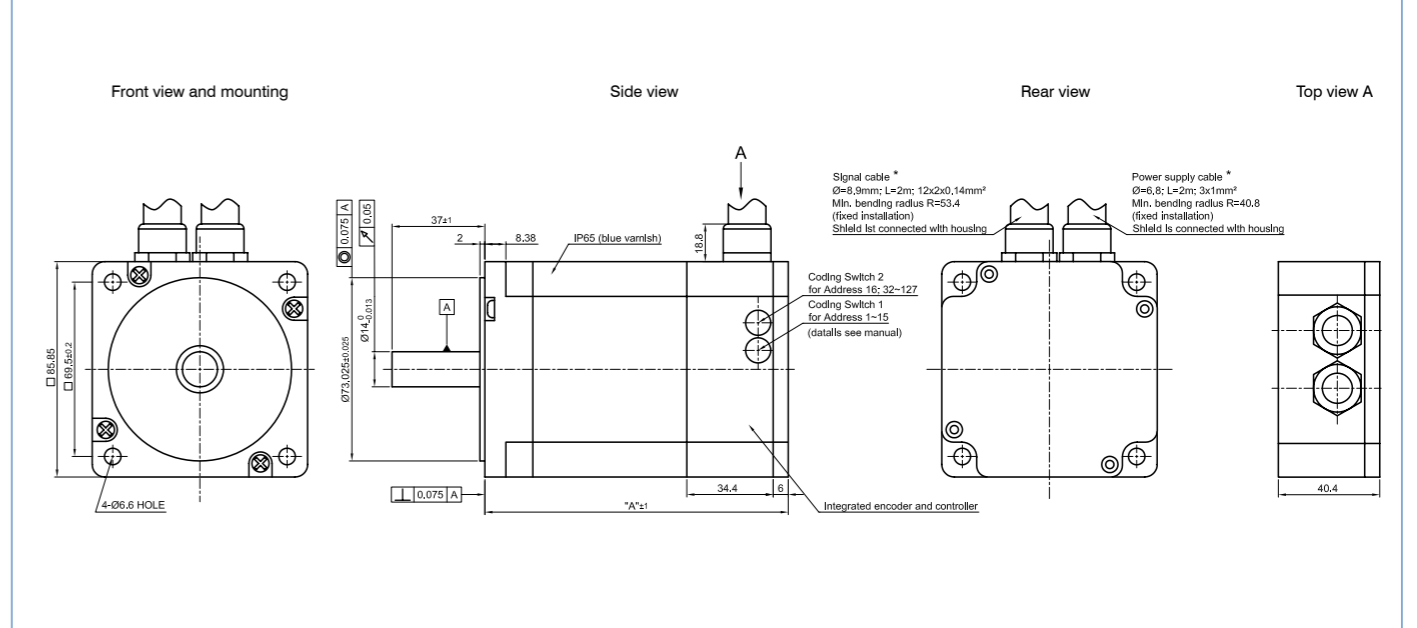

PD6-N8918...-S

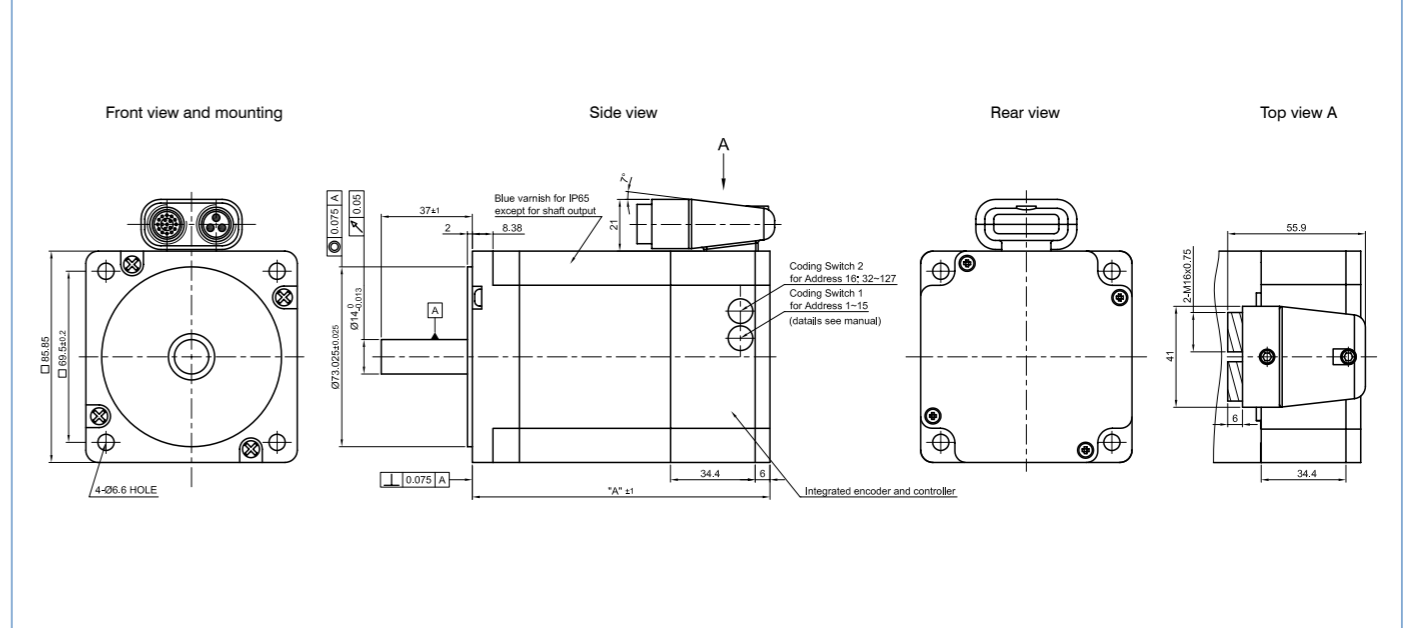

Speed/torque curves

